

Documentation for

## **KL2521-0000, KL2521-0024**

1-Channel Pulse Train Output Terminals, RS422 / 24V<sub>DC</sub>

Version: 1.8

Date: 2009-05-06

**BECKHOFF**

# Table of contents

<b>1. Foreword</b>	<b>1</b>
Notes on the documentation	1
Safety Instructions	2
<b>2. Product Overview</b>	<b>3</b>
Technical data	3
<b>3. Functional description</b>	<b>4</b>
Introduction	4
Resolution	5
Ramp function	5
Travel distance control	5
Output pattern	6
LED display	6
Connection	7
<b>4. Access from the user program</b>	<b>10</b>
Process Data	10
Register overview	11
Module-specific register description	12
Register communication	13
Control and Status Byte	15
<b>5. Appendix</b>	<b>16</b>
Support and Service	16

# Foreword

## Notes on the documentation

This description is only intended for the use of trained specialists in control and automation engineering who are familiar with the applicable national standards. It is essential that the following notes and explanations are followed when installing and commissioning these components.

## Liability Conditions

The responsible staff must ensure that the application or use of the products described satisfy all the requirements for safety, including all the relevant laws, regulations, guidelines and standards. The documentation has been prepared with care. The products described are, however, constantly under development. For that reason the documentation is not in every case checked for consistency with performance data, standards or other characteristics. None of the statements of this manual represents a guarantee (Garantie) in the meaning of § 443 BGB of the German Civil Code or a statement about the contractually expected fitness for a particular purpose in the meaning of § 434 par. 1 sentence 1 BGB. In the event that it contains technical or editorial errors, we retain the right to make alterations at any time and without warning. No claims for the modification of products that have already been supplied may be made on the basis of the data, diagrams and descriptions in this documentation.

## Delivery conditions

In addition, the general delivery conditions of the company Beckhoff Automation GmbH apply.

## Copyright

© This documentation is copyrighted. Any reproduction or third party use of this publication, whether in whole or in part, without the written permission of Beckhoff Automation GmbH, is forbidden.

# Safety Instructions

## State at Delivery

All the components are supplied in particular hardware and software configurations appropriate for the application. Modifications to hardware or software configurations other than those described in the documentation are not permitted, and nullify the liability of Beckhoff Automation GmbH.

## Description of safety symbols

The following safety symbols are used in this documentation. They are intended to alert the reader to the associated safety instructions..



**Danger**

This symbol is intended to highlight risks for the life or health of personnel.



**Attention**

This symbol is intended to highlight risks for equipment, materials or the environment.



**Note**

This symbol indicates information that contributes to better understanding.

# Product Overview

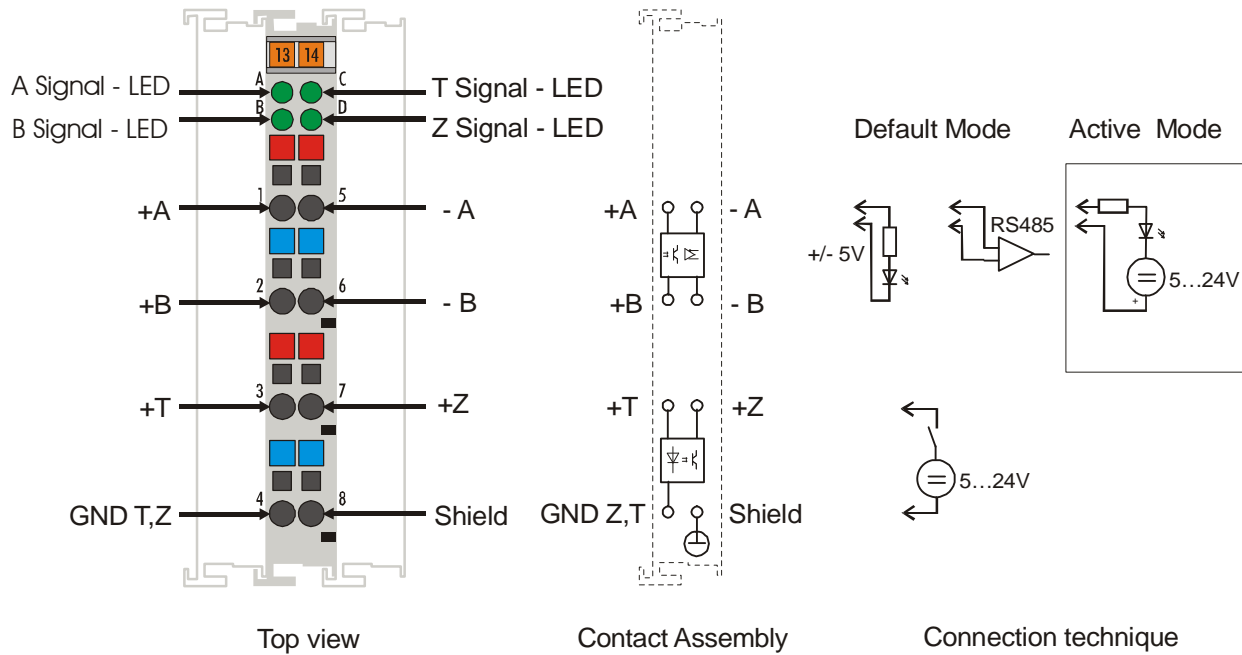

## Technical data

Technical data	KL2521-0000	KL2521-0024
Number of outputs	1 channel, 2 differential outputs (A, B)	
Load type*	ohmic, opto-coupler, differential inputs	
Rated load voltage*	5 V <sub>DC</sub> internal	5 V ... 24 V <sub>DC</sub> external
Output current	max. 0.05 A, RS485 specification	max. 0.5 A
Base frequency	100 Hz ... 500 kHz, 50 kHz default	
Mark/space ratio	50%	
Resolution	16 bits over one word in the fieldbus, 24 bits usable altogether	
Ramp calculation	2 ms / step	
Output cycle time	1 ms (synchronous to K-Bus)	
Delay time	0.6 ms after K-Bus cycle	
Number of outputs	2 (+T, +Z)	
Input current	2.3 to 2.8 mA at 5 V to 30 V	
Electrical isolation	500 V <sub>eff</sub> (K-Bus / field potential output / input)	
Current consumption from K-Bus	typ. 75 mA, max. 120 mA (load dependent)	
Input process image	24 bit I (16 bit in data, 8 bit status)	
Output process image	24 bit O (16 bit out data, 8 bit control)	
Configuration	Via the Bus Coupler with KS2000 or the controller	
Weight	approx. 50 g	
Permissible ambient temperature	0°C ... +55°C (during operation) -25°C ... +85°C (during storage)	
Permissible relative humidity	95%, no condensation	
Vibration / shock resistance	according to EN 60068-2-6 / EN 60068-2-27, EN 60068-2-29	
EMC resistance burst / ESD	according to EN 61000-6-2 / EN 61000-6-4	
Installation position	any	
Type of protection	IP20	

\*) depends on the hardware version of the terminal, see chapter *Connection*

# Functional description

## Introduction

The KL2521 output terminal generates a binary signal with a variable frequency. The peripheral side of the electronics is electrically isolated from the internal K-Bus, and therefore also from the fieldbus. The output frequency can be adjusted. 16 bit values (signed integer) can be provided for this adjustment through the controller's process image. These values modify the output frequency from zero up to a pre-selected maximum frequency in equal increments - there are 32767 (15 bits) steps in each direction (right/left).

process image	By default, the KL2521 terminal occupies three bytes in the process image. The mapping of the KL2521 can be set by means of the controller or by the Bus Coupler's configuration interface using the Beckhoff KS2000 configuration software.
operating modes	In addition to the FM (frequency modulation) operating mode, the KL2521 can also be used to control stepper motors with pulse-direction control (frq. cnt pulse mode). Incremental transducer simulation is another operating mode. It is possible to connect an incremental transducer directly. Such inputs are present on many servo amplifiers and frequency converters.
default setting	<p>The KL2521 is set to FM mode by default, with a basic frequency of 50 kHz and a resolution of 15 bits. The number of pulses output is read back into a 16 bit register. If the counter overflows a signal is sent to the controller. This is indicated by Status.3 (overflow) or Status.2 (under flow). In parallel with these two bits, Status. 6 is set as a general error bit. This makes the extension to more than 16 bits easier for the controller software to handle. The overflow can also be read from register 3 (internal 32 bit extension).</p> <p>The counter can be reset to 0 through Control.5. By default, the counter is cleared by a rising edge (Feature.4 = 1). If Feature.4 = 0, the function is level-controlled. If bit Feature.10 = 1, the counter is set by bit Control.5 to a value defined by register R0 (lower word) and register R1 (higher word).</p>
ramp function	<p>An internal ramp function raises/lowers the current frequency to the pre-set maximum frequency in accordance with the parameters set in registers 40/41. This is activated by FeatureBit.5. The base frequency for the ramp can be selected by FeatureBit.6. Status.1 is set while a ramp is being followed.</p> <p>The releasing of Control.0 can be used to deactivate the function. During operation this can also be done by Control.1. In this way the user can change the base frequency during operation very quickly. Setting Control.0 = 1 (confirmed by Status.0) the values in registers 38/39 are used instead of those in registers 36/37 (Control.0 = 0).</p> <p>The input signals T and Z are transferred directly from the terminal to the controller in the status byte (Status.4 / Status.5). The signals are not given any internal pre-processing.</p>

## Resolution

The base frequencies are specified with their resolution of 1 Hz per bit (GF1: registers 36, 37 or GF2: registers 38, 39). The terminal operates internally at 16 MHz with a resolution of 32 bits. This corresponds to a theoretical minimum step size of 0.0037 Hz/step over the entire frequency range. The output stage allows a maximum frequency of 500 kHz to be output.

## Ramp function

The terminal offers a facility for soft starting and stopping. The ramp gradient for starting can be set in register 40 with a precision of 10 or 1000 Hz/s (Feature.6). Register 41 performs the same function for stopping. The process data can be modified during transit of the ramp (Status.2), and the terminal then takes the new value as its target frequency.

## Travel distance control

If the "travel distance control" function is active (Feature.9), then a rising edge at Control.2 will result in drive to a fixed counter value. This value must previously be entered in register 0 (low word) and in register 1 (high word) at runtime. Time  $t_1$  is specified by the ramp time constant in register 40.  $t_2$  is reached at the maximum frequency  $f_1$  (register 2). Time  $t_3$  is determined by the ramp time constant in register 41 with which the slowing down frequency  $f_2$  (register 43) is achieved. When the given counter contents have been reached, the terminal switches the frequency to zero. In order to travel to a destination with precision, it is necessary that the time constant for the falling ramp is greater than that of the rising ramp by a certain factor. This is necessary so that the slowing down frequency is reached before the final counter state, so that the terminal does not drive up to the end point at full speed.

To explain in more detail: the KL2521 calculates the number of steps that are still to be taken in time  $t_2$  from time  $t_1$  and from the number of steps that have been taken. The calculation for stopping assumes the same number of steps as that found for starting up. The downward ramp must be a little steeper, approx. 10%, so that it is possible to reach the destination exactly in the remaining time  $t_3 + t_4 + t_5$ . This relationship changes with the maximum frequency.

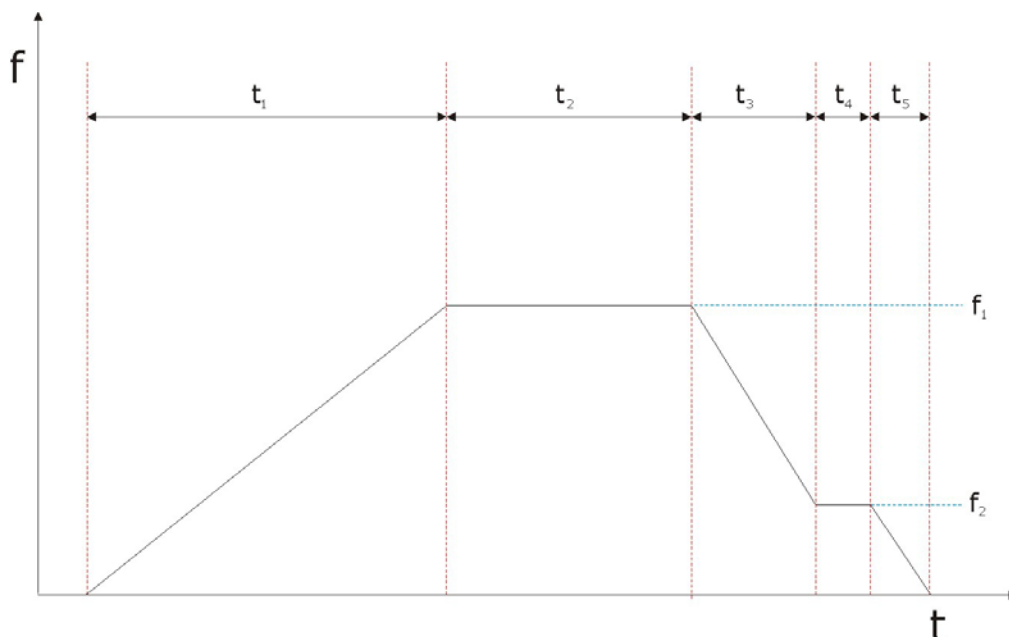

## Output pattern

operating modes

The pattern of pulses is output through channels A and B. It is possible to configure the necessary operating mode via feature register R32.

The operating modes differ primarily between the positive logic modes 0, 1 and 2 and the negative logic modes 4, 5 and 6.

Operating modes 2 and 6 simulate an incremental encoder, and permit direct connection to an evaluation unit such as a servoamplifier or frequency converter with an incremental encoder input.

Operating mode	Function
	Rotation to the right    Rotation to the left
<b>Frequency modulation positive logic ( BA 0 )</b>	A  B
<b>Pulse-direction control positive logic ( BA 1 )</b>	A  B
<b>Incremental encoder positive logic ( BA 2 )</b>	A  B
<b>Frequency modulation negative logic ( BA 4 )</b>	A  B
<b>Pulse-direction control negative logic ( BA 5 )</b>	A  B
<b>Incremental encoder negative logic ( BA 6 )</b>	A  B

## LED display

Signal LEDs

The 4 LEDs illuminate when the input and output signal levels are active. The illumination of the LEDs for the active frequency outputs A or B at higher frequencies can only be perceived as a glow at half brightness.

watchdog

When the watchdog is active (Feature.2 = 0!) the terminal will switch the outputs off or will output a value stored in register 35 if no new process data is transferred to the terminal within 100 ms.

## Connection

### Connection of the inputs

Circuit examples for output to A. The same principles apply to output B.

The optically isolated inputs are protected from overload by a current limiter. The operating voltage can lie in the range between 5 V ... 24 V<sub>DC</sub> without any additional external circuitry. The GND connection is the common ground for the two inputs, T and Z.

The circuit diagram shows the internal circuitry of the two inputs:

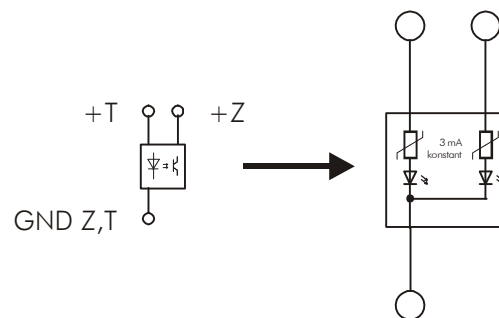

### Connection of the outputs

Outputs A and B on the KL2521 can be used with different types of connection. An integrated DC/DC converter supplies the outputs stage of the two channels, A and B, with an electrically isolated 5 V power supply.

#### Connection to a RS485/RS232 receiver

The output can be operated as RS485 or as RS232 output. The circuit generates the necessary differential signals.

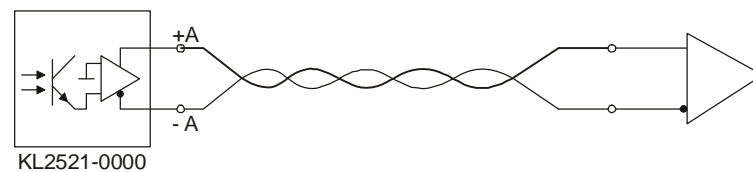

#### Connection to an optocoupler (without external power supply)

The outputs can be used for direct connection of an optocoupler. The output stage supplies the necessary output current using an internal 5 V power supply.

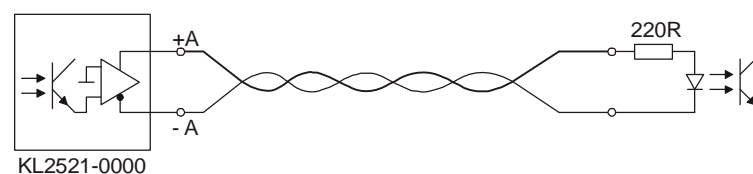

**Connection to an optocoupler (with external power supply)**

For connection to inputs with large internal impedances, an external power supply (of up to 24 V) can be used in order to create the necessary current.



The operation with external power supply depends on the hardware version of the terminal:

- until hardware version 03 you can use the standard terminal KL2521-0000 for this.
- from hardware version 04 this is only possible with special terminal KL2521-0024, that is especially optimized for this application!  
But because the KL2521-0024 misses the internal power supply (5 V), it is not suitable for connection of a RS232/485 receiver or an optocoupler without external power supply.

Check the hardware version

The firmware and hardware version (delivery state) can be found in the serial number printed at the side of the terminal.

Structure of the serial number: WW YY FF HH

WW - week of production (CW, calendar week)

YY - year of production

FF - firmware version

HH - hardware version

Example with ser. no.: 12 06 4F 03:

12 - week of production 12

06 - year of production 2006

4F - firmware version 4F

03 - hardware version 03

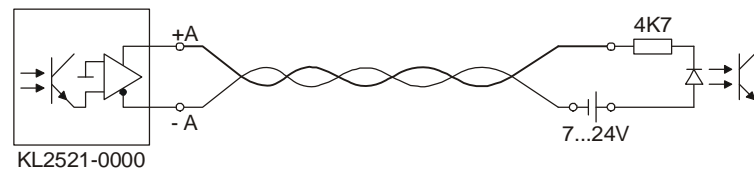
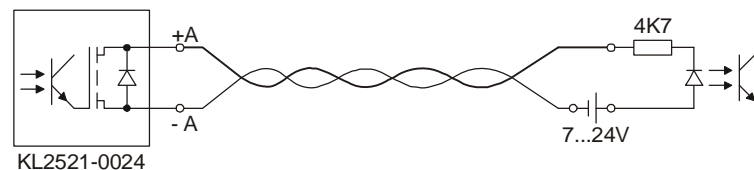
**Until hardware version 03****Instead of hardware version 04 (or higher) use special terminal KL2521-0024**

**KL2521-0024: Connection to external electronics**

For connection to external electronics pay attention that KL2521-0024's terminal points A- of the first and B- of the second channel are internally connected to each other.

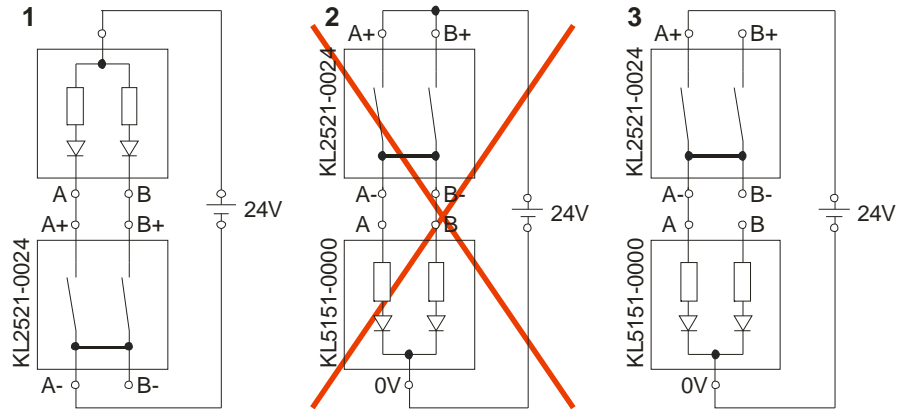

This allows two channel connections of external electronics, if the KL2521-0024 switches the grounds of the external device, as shown in **example 1**.



The Beckhoff incremental encoder interface terminals KL5111, KL5121, KL5151 and KL5152 require the switching of the positive voltage.

Because the terminal points A- and B- of KL2521-0024 are internally bridged, the KL2521-0024 is not able to switch the two inputs of the KL5151-0000, shown in **example 2**, independently of each other. So this red crossed application doesn't make sense!

But you can use one channel of the KL2521-0024 to switch one channel of the KL5151-0000, as shown in **example 3**.

# Access from the user program

## Process Data

Input format: Two's complement representation (integer - 1 corresponds to 0xFFFF)  
 or sign / amount representation (Feature.3) (integer -1 corresponds to 0x8001)

The output frequency is specified within maximum resolution of 15 bits (the 16th bit is used to specify the direction).  
 Negative process data results in rotation in the opposite direction. In this case, the internal counter counts to decreasing values.

(relative data) The output frequency is based on the base frequency that is set in registers 36 to 39 and the process data (see table).

Output frequency = base frequency x process data / 32767  
 Highest resolution = 125 mHz

Example:  
 Base frequency = 100,000 Hz (maximum selected output frequency)  
 Process data = 0x00FF (255<sub>dec</sub>)  
 Output frequency = 778.22 Hz

(direct data) It is possible to enter the frequency directly (Feature.7).  
 In this case the process data is multiplied by the factor contained in register 42, and directly written to the synthesis chip.

Output frequency = frequency factor x process data x 10 mHz  
 Highest resolution = 10 mHz

Example:  
 Frequency factor = 100  
 Process data = 0x00FF (255<sub>dec</sub>)  
 Output frequency = 255 Hz

relative data:

	Process data	Output value
	0x0000	0% DC
	0x3FFF	50% of the base frequency, rotation to the right
	0x7FFF	100% of the base frequency, rotation to the right
Two's complement	0xC000	50% of the base frequency, rotation to the left
	0x8000	100% of the base frequency, rotation to the left
Sign-amount	0xBFFF	50% of the base frequency, rotation to the left
	0xFFFF	100% of the base frequency, rotation to the left

## Register overview

Register set

Address	Description	Default value	R/W	Memory medium
R0	Target counter state (low word)	0x0000 (0 <sub>dec</sub> )	R/W	RAM
R1	Target counter state (high word)	0x0000 (0 <sub>dec</sub> )	R/W	RAM
R2	Maximum frequency	0x0000 (0 <sub>dec</sub> )	R/W	RAM
R3	Counter extension (high word)	0x0000 (0 <sub>dec</sub> )	R	RAM
R4	reserved	0x0000 (0 <sub>dec</sub> )	R	
...	...	...	...	...
R7	Command register	0x0000 (0 <sub>dec</sub> )	R/W	RAM
R8	Terminal type	0x09D9 (2521 <sub>dec</sub> )	R	ROM
R9	Firmware version number	0x3446 (4F <sub>ASCII</sub> )	R	ROM
R10	Multiplex shift register	0x0118 (280 <sub>dec</sub> )	R	ROM
R11	Signal channels	0x0118 (280 <sub>dec</sub> )	R	ROM
R12	Minimum data length	0x1818 (6468 <sub>dec</sub> )	R	ROM
R13	Data structure	0x0004 (4 <sub>dec</sub> )	R	ROM
R14	reserved	0x0000 (0 <sub>dec</sub> )	R	
R15	Alignment register	variable	R/W	RAM
R16	Hardware version number	0x0003 (3 <sub>dec</sub> )	R/W	EEPROM
R17	reserved	0x0000 (0 <sub>dec</sub> )	R/W	
...	...	...	...	...
R30	reserved	0x0000 (0 <sub>dec</sub> )	R/W	
R31	Code word register	variable	R/W	RAM
R32	Feature register	0x0030 (48 <sub>dec</sub> )	R/W	EEPROM
R33	reserved	0x0000 (0 <sub>dec</sub> )	R/W	
R34	reserved	0x0000 (0 <sub>dec</sub> )	R/W	
R35	User's switch-on value	0x0000 (0 <sub>dec</sub> )	R/W	EEPROM
R36*	Base frequency 1 (low word)	0xC350 (50000 <sub>dec</sub> )	R/W	EEPROM
R37*	Base frequency 1 (high word)	0x0000 (0 <sub>dec</sub> )	R/W	EEPROM
R38*	Base frequency 2 (low word)	0x86A0 (34464 <sub>dec</sub> )	R/W	EEPROM
R39*	Base frequency 2 (high word)	0x0001 (1 <sub>dec</sub> )	R/W	EEPROM
R40	Ramp time constant (rising, see feature register)	0x03E8 (1000 <sub>dec</sub> )	R/W	EEPROM
R41	Ramp time constant (falling, see feature register)	0x03E8 (1000 <sub>dec</sub> )	R/W	EEPROM
R42	Frequency factor (direct input, (digit x 10 mHz)	0x0064 (100 <sub>dec</sub> )	R/W	EEPROM
R43	Slowing down frequency (travel distance control)	0x0032 (50 <sub>dec</sub> )	R/W	EEPROM
R44	reserved	0x0000 (0 <sub>dec</sub> )	R/W	
...	...	...	...	...
R61	reserved	0x0000 (0 <sub>dec</sub> )	R/W	

\*) The change of the base frequency needs a reset for activation.

## Module-specific register description

### R7: Command register [0x0000]

For a standard command to be executed, it is first necessary for the user code word, 0x1235, to be entered into register R31.

### Command 0x7000: Restore Factory Settings

Entering 0x7000 in register R7 restores the factory settings for the following registers:

<b>R32:</b>	0x0030	(48 <sub>dec</sub> )	<b>R38:</b>	0x86A0	(34464 <sub>dec</sub> )
<b>R33:</b>	0x0000	(0 <sub>dec</sub> )	<b>R39:</b>	0x0001	(1 <sub>dec</sub> )
<b>R34:</b>	0x0000	(0 <sub>dec</sub> )	<b>R40:</b>	0x03E8	(1000 <sub>dec</sub> )
<b>R35:</b>	0x0000	(0 <sub>dec</sub> )	<b>R41:</b>	0x03E8	(1000 <sub>dec</sub> )
<b>R36:</b>	0xC350	(50000 <sub>dec</sub> )	<b>R42:</b>	0x0064	(100 <sub>dec</sub> )
<b>R37:</b>	0x0000	(0 <sub>dec</sub> )	<b>R43:</b>	0x0032	(50 <sub>dec</sub> )

### R32: Feature register [0x0030]

The feature register specifies the terminal's operating mode.

Feature bit no.			Description of the operating mode	
<b>Bit 1 – Bit 0</b>	-		No function	
<b>Bit 2</b>	0		[0] Watchdog timer active The watchdog timer is switched on by default. Either the manufacturer's or the user's switch-on value is output if the watchdog overflows.	
<b>Bit 3</b>	1		[0] Sign / amount representation [0] Sign / amount representation is active instead of two's-complement representation. (-1 = 0x8001)	
<b>Bit 4</b>	1		[1] The counter is cleared by a rising edge in the Counter_Clear bit in the control byte	
<b>Bit 5</b>	1		[1] Ramp function active	
<b>Bit 6</b>	0/1		[0] Ramp base frequency 0: 10 Hz/s 1: 1000 Hz/s	
<b>Bit 7</b>	0/1		[0] Input mode 0: relative 1: direct	
<b>Bit 8</b>	0/1		[0] Behavior when watchdog triggered 0: Manufacturer's switch-on value 1: User's switch-on value	
<b>Bit 9</b>	1		[0] Travel distance control active	
<b>Bit 10</b>	0/1		[0] Counter 0: delete 1: set	
<b>Bit 12 – Bit 11</b>	-		No function	
<b>Bit 15 – Bit 13</b>	<b>pos. logic</b>	<b>neg. logic</b>	[000] <b>Operating mode</b>	<b>Value range</b> 0 – 500 kHz
	000	100	Frequency modulation	
	001	101	Pulse-direction control	
	010	110	Incremental encoder	

## Register communication

Register access via process data transfer  
 Bit 7=1: register mode

When bit 7 of the control byte is set, the first two bytes of the user data are not used for process data transfer, but are written into or read out of the terminal's register.

Bit 6=0: read  
 Bit 6=1: write

In bit 6 of the control byte, you define whether a register is to be read or written. When bit 6 is not set, a register is read without modification. The value can be taken from the input process image.

When bit 6 is set, the user data is written into a register. The operation is concluded as soon as the status byte in the input process image has supplied an acknowledgement (see examples).

Bits 0 to 5: address

The address of the register to be addressed is entered in bits 0 to 5 of the control byte.

### Control byte in the register mode

Bit Name	7	6	5	4	3	2	1	0
	REG=1	W/R	A5	A4	A3	A2	A1	A0

REG = 0: Process data transfer  
 REG = 1: Access to register structure  
 W/R = 0: Read register  
 W/R = 1: Write register  
 A5...A0 = Register address  
 A total of 64 registers can be addressed with the addresses A5...A0.

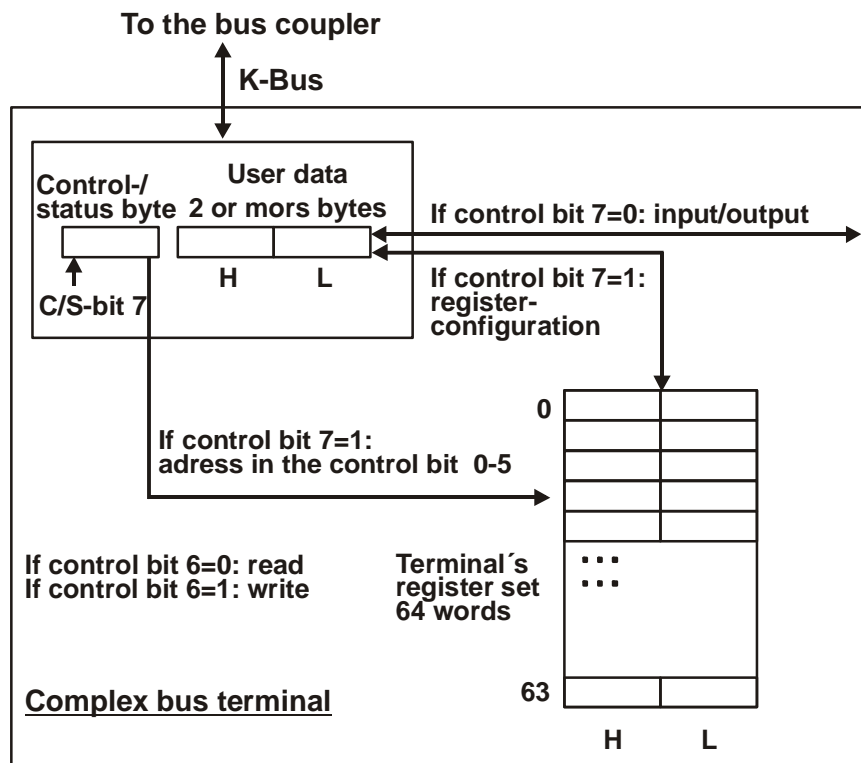

The control or status byte occupies the lowest address of a logical channel. The corresponding register values are located in the following 2 data bytes (the BK2000 is an exception to the rule: here, an unused data byte is inserted after the control or status byte, thus setting the register value to a word limit).

## Examples for Register Communication

### Example 1

Reading register 8 in the BK2000 with a KI3022 and the end terminal.

If the following bytes are transferred from the controller to the terminal,

<b>Byte</b>	Byte3	Byte2	Byte1	Byte0
<b>Name</b>	Data OUT, low byte	Data OUT, high byte	Not used	Control
<b>Value</b>	0xXX	0xXX	0xXX	0x88

the terminal returns the following type designation (0x0BCE corresponds to the unsigned integer 3022).

<b>Byte</b>	Byte3	Byte2	Byte1	Byte0
<b>Name</b>	Data IN, low byte	Data IN, high byte	Not used	Status
<b>Value</b>	0xCE	0x0B	0x00	0x88

### Example 2

Writing register 31 in the BK2000 with an intelligent terminal and the end terminal.

If the following bytes (user code word) are transferred from the controller to the terminal,

<b>Byte</b>	Byte3	Byte2	Byte1	Byte0
<b>Name</b>	Data OUT, low byte	Data OUT, high byte	Not used	Control
<b>Value</b>	0x35	0x12	0xXX	0xDF

the user code word is set and the terminal returns the register address with the bit 7 for register access and the acknowledgement.

<b>Byte</b>	Byte3	Byte2	Byte1	Byte0
<b>Name</b>	Data IN, low byte	Data IN, high byte	Not used	Status
<b>Value</b>	0x00	0x00	0x00	0x9F

## Control and Status Byte

### Control Byte in process data exchange

The Control Byte is sent to the terminal from the controller. It can be used in register mode (REG = 1) or in process data exchange (REG = 0).

Bit	7	6	5	4	3	2	1	0
Name	Reg_Access	0	Cnt_Clr	0	0	Go_Counter	Ramp_Dis	Freq_Sel

Bit	Name	Function
7	Reg_Access	0: Register communication inactive (process data exchange)
5	Cnt_Clr	The contents of the counter is cleared or set (Feature.10) by this bit. Any overflow or underflow bits that might be set are also cleared by this bit. The process can be edge triggered or level triggered (Feature.4).
2	Go_Counter	If travel distance control is active (Feature.9), then a pre-set counter value is approached when the bit is set
1	Ramp_DisS	Operation of the ramp function is cancelled, in spite of Feature.5 being active; if travel distance control is active, it is interrupted by this bit
0	Freq_Sel	Rapid change of the base frequency (only if the ramp function is inactive) 0: Base frequency 1 (registers 36 / 37) 1: Base frequency 2 (registers 38 / 39)

### Status Byte in process data exchange

The Status Byte is sent from the module to the controller.

Bit	7	6	5	4	3	2	1	0
Name	Reg_Access	Error	Input_Z	Input_T	Overflow	Underflow	Ramp_Active	Sel_Ack/ End_Counter

Bit	Name	Function
7	Reg_Access	0: acknowledge for process data exchange
6	Error	General error bit, included with overflow/underflow
5	Input_Z	End position reached
4	Input_T	The actual value when the device is connected does not agree with the set value of the connected device.
3	Overflow	This bit is set if the 16-bit counter overflows (65535 -> 0). It is reset when the counter exceeds one third of its measuring range (21845 -> 21846) or immediately an underflow occurs.
2	Underflow	This bit is set if the 16-bit counter underflows (0 -> 65535). It is reset when the counter drops below two thirds of its measuring range (43690 -> 43689) or immediately an overflow occurs.
1	Ramp_Active	Ramp is currently being followed
0	Sel_Ack/ End_Counter	Confirms the change of base frequency. At activated travel distance control: target counter value reached

The change of the base frequency needs a reset for activation.

# Appendix

## Support and Service

Beckhoff and their partners around the world offer comprehensive support and service, making available fast and competent assistance with all questions related to Beckhoff products and system solutions.

### Beckhoff Support

Support offers you comprehensive technical assistance, helping you not only with the application of individual Beckhoff products, but also with other, wide-ranging services:

- world-wide support
- design, programming and commissioning of complex automation systems
- and extensive training program for Beckhoff system components

Hotline: +49(0)5246/963-157  
Fax: +49(0)5246/963-9157  
e-mail: support@beckhoff.com

### Beckhoff Service

The Beckhoff Service Center supports you in all matters of after-sales service:

- on-site service
- repair service
- spare parts service
- hotline service

Hotline: +49(0)5246/963-460  
Fax: +49(0)5246/963-479  
e-mail: service@beckhoff.com

You will find further support and service addresses on our Internet pages under <http://www.beckhoff.com>.

### Beckhoff Headquarters

Beckhoff Automation GmbH  
Eiserstr. 5  
33415 Verl  
Germany

Phone: +49(0)5246/963-0  
Fax: +49(0)5246/963-198  
e-mail: info@beckhoff.com

The addresses of Beckhoff's branch offices and representatives round the world can be found on her internet pages: <http://www.beckhoff.com>.

You will also find further documentation for Beckhoff components there.