

Documentation for

KL1512

Up/Down-Counter Terminal, 24 V_{DC}, 1 kHz

Version: 1.0.3
Date: 2006-10-20

BECKHOFF

Table of Contents

1	Foreword	1
1.1	Notes on the documentation	1
1.1.1	Liability Conditions	1
1.1.2	Delivery conditions	1
1.1.3	Copyright	1
1.2	Safety Instructions	2
1.2.1	State at Delivery	2
1.2.2	Description of safety symbols	2
2	Product Overview	3
2.1	Technical data	3
2.2	Functional Description	4
3	Terminal configuration	4
3.1	Register Overview	6
3.2	Register description	6
3.2.1	General register description	6
3.2.2	Terminal-specific register description	9
3.3	Control and Status Byte	9
3.4	Register communication with KL1512	10
3.4.1	Examples for Register Communication	11
4	Appendix	12
4.1	Mapping in the bus coupler	12
4.2	Support and Service	13
4.2.1	Beckhoff Support	13
4.2.2	Beckhoff Service	13
4.2.3	Beckhoff company headquarters	13

1 Foreword

1.1 Notes on the documentation

This description is only intended for the use of trained specialists in control and automation engineering who are familiar with the applicable national standards. It is essential that the following notes and explanations are followed when installing and commissioning these components.

1.1.1 Liability Conditions

The responsible staff must ensure that the application or use of the products described satisfy all the requirements for safety, including all the relevant laws, regulations, guidelines and standards. The documentation has been prepared with care. The products described are, however, constantly under development. For that reason the documentation is not in every case checked for consistency with performance data, standards or other characteristics. None of the statements of this manual represents a guarantee (Garantie) in the meaning of § 443 BGB of the German Civil Code or a statement about the contractually expected fitness for a particular purpose in the meaning of § 434 par. 1 sentence 1 BGB. In the event that it contains technical or editorial errors, we retain the right to make alterations at any time and without warning. No claims for the modification of products that have already been supplied may be made on the basis of the data, diagrams and descriptions in this documentation.

1.1.2 Delivery conditions

In addition, the general delivery conditions of the company Beckhoff Automation GmbH apply.

1.1.3 Copyright

© This documentation is copyrighted. Any reproduction or third party use of this publication, whether in whole or in part, without the written permission of Beckhoff Automation GmbH, is forbidden.

1.2 Safety Instructions

1.2.1 State at Delivery

All the components are supplied in particular hardware and software configurations appropriate for the application. Modifications to hardware or software configurations other than those described in the documentation are not permitted, and nullify the liability of Beckhoff Automation GmbH.

1.2.2 Description of safety symbols

The following safety symbols are used in this documentation. They are intended to alert the reader to the associated safety instructions..



Danger

This symbol is intended to highlight risks for the life or health of personnel.



Attention

This symbol is intended to highlight risks for equipment, materials or the environment.



Note

This symbol indicates information that contributes to better understanding.

2 Product Overview

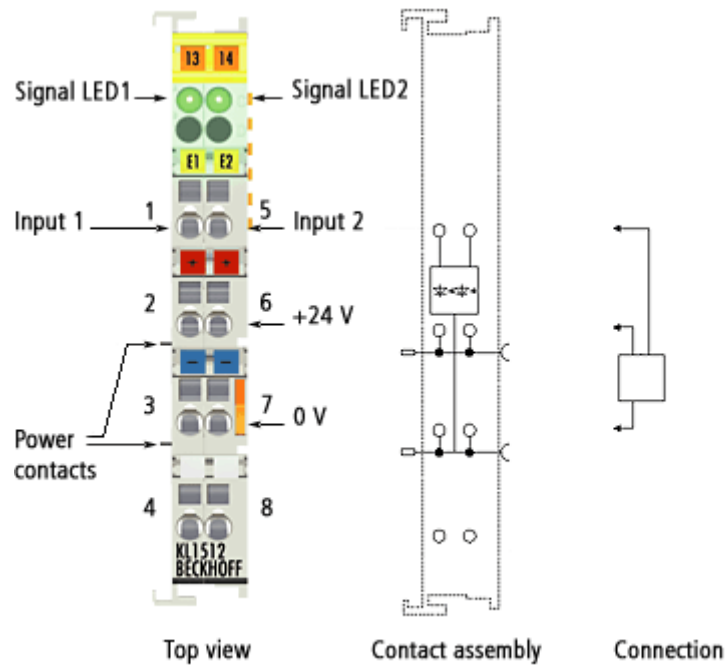

2.1 Technical data

Product name	KL1512
Number of counters	2
Rated load voltage	24 V _{DC} (-15% / +20%)
'0' signal voltage	-3 V ... 5 V (EN61131-3, Typ 1)
'1' signal voltage	15 V ... 30 V (EN61131-3, Typ 1)
Input current	typical 8 mA. (EN61131-3, Typ 1)
Counting frequency	maximum 1 kHz
Counter depth	16 bit
Current consumption from K-Bus	typical 50 mA
Electrical isolation	500 V _{rms} (K-Bus / field voltage)
Bit width in the process image	2 x 16 bits data, 2 x 8 bits control/status
Configuration	no address settings, configuration via Control and Status Byte
Weight	app. 55 g
Operating temperature	0°C ... +55°C
Storage temperature	-25°C ... +85°C
Relative humidity	95%, no condensation
Vibration / Shock resistance	conforms to EN 60068-2-6 / EN 60068-2-27, EN 60068-2-29
EMC resistance burst / ESD	conforms to EN 61000-6-2 / EN 61000-6-4
Installation position	any
Type of protection	IP20

2.2 Functional Description

The input terminal KL1512 counts binary pulses and transmits the current value to the higher-level control system.

The maximum input frequency is limited to 1 kHz. The minimum pulse width of the input signal is 500 microseconds. This means, not mark nor space of the input signal may be shorter than 500 microseconds!

The counters react to the rising edge of the input signal.

LED display

The LEDs indicate the states of inputs 1 and input 2.

Process data
Standard output format

6 bytes (2 bytes of user information data and 1 control/status byte per channel) are mapped. The process data presents themselves as follows per channel:

- 1 Byte Control/Status
- 16 Bit unsigned Integer

Mapping of the terminal is described in further detail in the appendix.

3 Terminal configuration



Note

The terminal can be configured and parameterized by way of the internal register structure. Each terminal channel is mapped in the bus coupler. The terminal's data is mapped differently in the bus coupler's memory depending on the type of the bus coupler and on the set mapping configuration (e.g. Motorola/Intel format, word alignment etc.).

Contrary to the analog and output terminals, in the case of the KL1512 the control and status byte is always also mapped, regardless of the field bus system used.

Lightbus coupler BK2000

When using the Lightbus coupler BK2000, the KL1512 is automatically mapped with 6 bytes of input data and 6 bytes of output data.

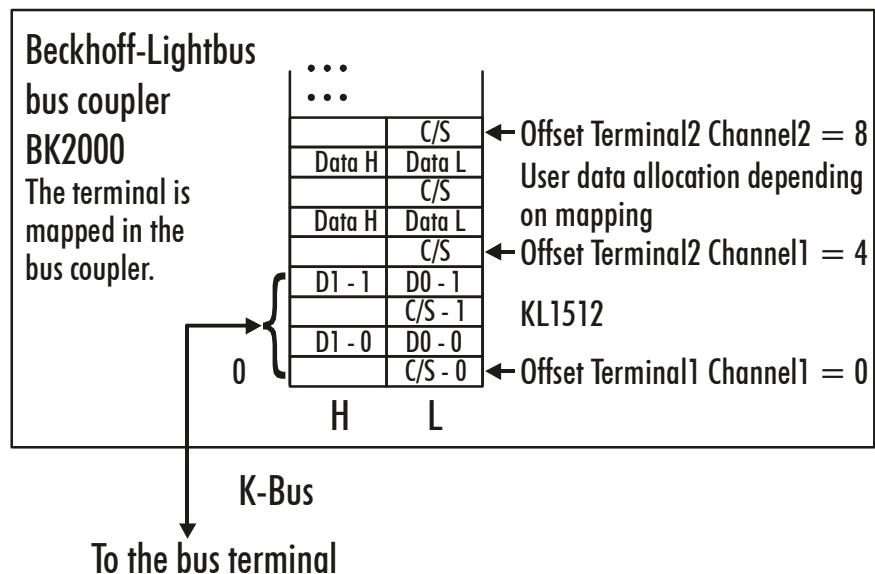

Profibus coupler BK3000

When using the Profibus coupler BK3000, the KL1512 is automatically mapped with 6 bytes of input data and 6 bytes of output data.

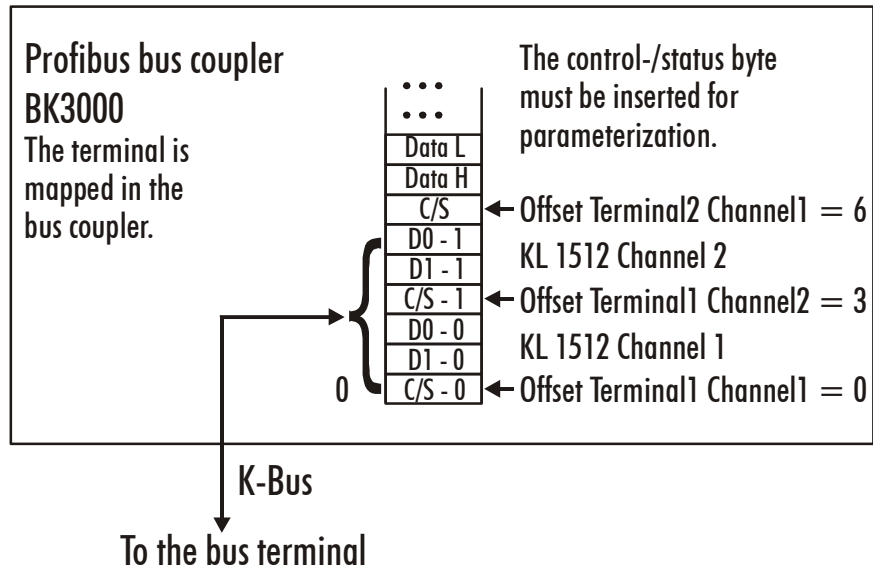

Interbus coupler BK4000

When using the Interbus coupler BK4000, the KL1512 is automatically mapped with 6 bytes of input data and 6 bytes of output data.

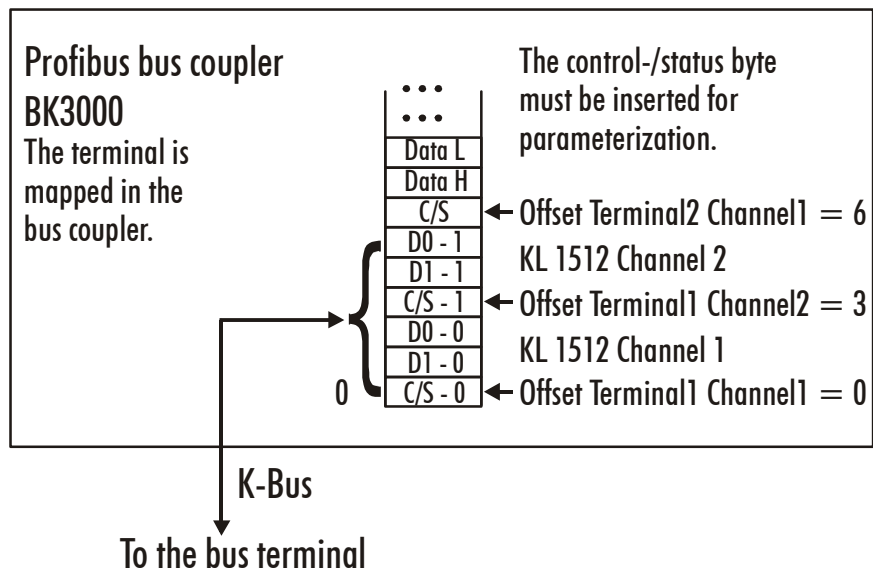

Other bus couplers and further information

You will find further information on the mapping configuration of bus couplers in the annex of the respective bus coupler manual under the heading of *Configuration of masters*.



Note

Parameterization with the KS2000 software

In the appendix it exists an outline of the possible mapping configurations in dependency of the adjustable parameters.

Using the KS2000 configuration software, the parameterization operations can be carried out independently of the field bus system via the bus couplers serial interface.

3.1 Register Overview

Register No.	Description	Default	R/W	Storage medium
R0	not used	0x0000	R	
...
R5	not used	0x0000	R	
R6	Diagnostic register – not used	0x0000	R	
R7	Command register - not used	0x0000	R	
R8	Terminal type	0x05E8 (1512)	R	ROM
R9	Software version number	0x????	R	ROM
R10	Multiplex-shift register	0x0130	R	ROM
R11	Signal channels	0x0228	R	ROM
R12	minimum data length	0x1818	R	ROM
R13	Data structure	0x0004	R	ROM
R14	not used	0x0000	R	
R15	Alignment-register	variable	R/W	RAM
R16	Hardware version number	0x????	R/W	SEEROM
R17	not used	0x0000	R/W	SEEROM
...
R30	not used	0x0000	R/W	SEEROM
R31	Code word register	variable	R/W	RAM
R32	not used	0x0000	R/W	SEEROM
R33	not used	0x0000	R/W	SEEROM
...
R63	not used	0x0000	R/W	SEEROM

3.2 Register description

The complex terminals can be adjusted to different operating modes or functionalities. The *General Description of Register* describes the contents of the registers, which are identical for all complex terminals.

The terminal-specific registers are explained in the section following to it.

The access to the internal registers of the terminal is described in the section Register Communication.

3.2.1 General register description

Complex terminals that possess a processor are capable of bidirectionally exchanging data with the higher-level control system. Below, these terminals are referred to as intelligent bus terminals. They include the analog inputs, the analog outputs, serial interface terminals (RS485, RS232, TTY etc.), counter terminals, encoder interfaces, SSI interfaces, PWM terminals and all other parameterizable terminals.

Internally, all intelligent terminals possess a data structure that is identical in terms of its essential characteristics. This data area is organized in words and embraces 64 registers. The essential data and parameters of the terminal can be read and adjusted by way of the structure. Function calls with corresponding parameters are also possible. Each logical channel of an intelligent terminal has such a structure (therefore, 4-channel analog terminals have 4 register sets).

This structure is broken down into the following areas:

Register	Application
0 to 7	Process variables
8 to 15	Type register
16 to 30	Manufacturer parameters
31 to 47	User parameters
48 to 63	Extended user area

Process variables

R0 to R7: Registers in the terminal's internal RAM

The process variables can be used in addition to the actual process image and their functions are specific to the terminal.

R0 to R5: Terminal specific registers

The function of these registers depends on the respective terminal type (see terminal-specific register description).

R6: Diagnostic register

The diagnostic register may contain additional diagnostic information. In the case of serial interface terminals, for example, parity errors that have occurred during data transfer are indicated.

R7: Command register

High-Byte_Write = function parameter

Low-Byte_Write = function number

High-Byte_Read = function result

Low-Byte_Read = function number

Type registers

R8 to R15: Registers in the terminal's internal ROM

The type and system parameters are programmed permanently by the manufacturer and can only be read by the user but cannot be modified.

R8: Terminal type:

The terminal type in register R8 is needed to identify the terminal.

R9: Firmware version X.y

The firmware version can be read as an ASCII character string.

3.2.1.1 R10: Data length

R10 contains the number of multiplexed shift registers and their length in bits.

The bus coupler sees this structure.

R11: Signal channels

In comparison with R10, the number of logically existing channels is located here. For example, one physically existing shift register may consist of several signal channels.

R12: Minimum data length

The respective byte contains the minimum data length of a channel to be transferred. If the MSB is set, then the control/status byte is not necessarily needed for the function of the terminal and, with appropriate configuration of the coupler, is not transferred to the control system.

R13: Data type register

Data type register	
0x00	Terminal without valid data type
0x01	Byte array
0x02	1 byte n bytes structure
0x03	Word array
0x04	1 byte n words structure
0x05	Double word array
0x06	1 byte n double words structure
0x07	1 byte 1 double word structure
0x08	1 byte 1 double word structure
0x11	Byte-array with a variable logical channel length
0x12	1 byte n bytes structure with a variable logical channel length (eg 60xx)
0x13	Word-array with a variable logical channel length
0x14	1 byte n words structure with a variable logical channel length
0x15	Double word array with a variable logical channel length
0x16	1 byte n double words structure with a variable logical channel length

R14: not used**R15: Alignment bits (RAM)**

The analog terminal is set to a byte limit in the terminal bus with the alignment bits.

Manufacturer parameters

R16 to R30: Manufacturer parameter area (SEEPROM)

The manufacturer parameters are specific to each terminal type. They are programmed by the manufacturer but can also be modified from the control system. The manufacturer parameters are stored permanently in a serial EEPROM and are therefore not destroyed by power failures. These registers can only be modified after setting a code word in R31.

User parameters

R31 to R47: User parameter area (SEEPROM)

The user parameters are specific to each terminal type. They can be modified by the programmer. The user parameters are stored permanently in a serial EEPROM in the terminal and cannot be destroyed by power failures. The user area is write protected over a Codeword.



Note

R31: Code word register in the RAM

The code word **0x1235** must be entered here to enable modification of parameters in the user area. Write-protection is set if a different value is entered in this register. When write protection is inactive, the code word is returned during reading of the register. The register contains the value zero when write protection is active.

R32: Feature-register

This register defines the operating modes of the terminal. For example, a user-specific scaling can be activated for the analog I/Os.

R33 to R47

Registers that depend on the terminal type

Extended application area

R47 to R63

These registers have not yet been implemented.

3.2.2 Terminal-specific register description

The KL1512 has no terminal specific registers!

3.3 Control and Status Byte

The control byte is transmitted from the controller to the terminal. It can be used

- in register mode (REG = 1_{bin}) or
- during process data exchange (REG = 0_{bin}).

Control byte during process data exchange

The control byte triggers various actions in the counter terminal KL1512 during process data exchange:

Bit Name	7	6	5	4	3	2	1	0
	REG=0	0	CNT_SET	CNT_INH	0	CNT_OVL	CNT_CLR	CNT_DEC

Bit	Name	Function
7	REG	0 for Process data mode
6	0	not used
5	CNT_SET	The counter is set to the value that is specified via the process data. Setting of the counter is edge controlled.
4	CNT_INH	If this bit is set, the counter is stopped. The present counter value is saved.
3	0	not used
2	CNT_OVL	If this bit is set, the counter is stopped, - if it reaches 0xFFFF while counting forwards - if it reaches 0x0000 while counting backwards
1	CNT_CLR	The counter is set to the value 0x0000. Setting of the counter is edge controlled.
0	CNT_DEC	If this bit is set, the counter is decremented with every positive edge.

Status byte during process data exchange

The status byte is transferred from the terminal to the control system. It acknowledges the bits of the control byte.:

Bit Name	7	6	5	4	3	2	1	0
	REG=0	0	SET_ACK	INH_ACK	0	OVL_ACK	CLR_ACK	DEC_ACK

Bit	Name	Function
7	REG	0 for Process data mode
6	0	not used
5	SET_ACK	Acknowledgement for CNT_SET: The data for setting the counter was taken over by the terminal.
4	INH_ACK	Acknowledgement for CNT_INH: The counter is stopped.
3	0	not used
2	OVL_ACK	Acknowledgement for CNT_OVL: If this bit is set, the counter is stopped, - if it reaches 0xFFFF while counting forwards - if it reaches 0x0000 while counting backwards
1	CLR_ACK	Acknowledgement for CNT_CLR: The counter is set to the value 0x0000. Setting of the counter is edge controlled.
0	DEC_ACK	Acknowledgement for CNT_DEC: If this bit is set, the counter is decremented with every positive edge.

3.4 Register communication with KL1512

Register access via process data transfer
Bit 7=1: register mode

When bit 7 of the control byte is set, the first two bytes of the user data are not used for process data transfer, but are written into or read out of the terminal's register.

Bit 6=0: read
Bit 6=1: write

In bit 6 of the control byte, you define whether a register is to be read or written. When bit 6 is not set, a register is read without modification. The value can be taken from the input process image.

When bit 6 is set, the user data is written into a register. The operation is concluded as soon as the status byte in the input process image has supplied an acknowledgement (see examples).

Bits 0 to 5: address

The address of the register to be addressed is entered in bits 0 to 5 of the control byte.

Control byte in the register mode

Bit	7	6	5	4	3	2	1	0
Name	REG=1	W/R	A5	A4	A3	A2	A1	A0

REG = 0: Process data transfer

REG = 1: Access to register structure

W/R = 0: Read register

W/R = 1: Write register

A5...A0 = Register address

A total of 64 registers can be addressed with the addresses A5...A0.

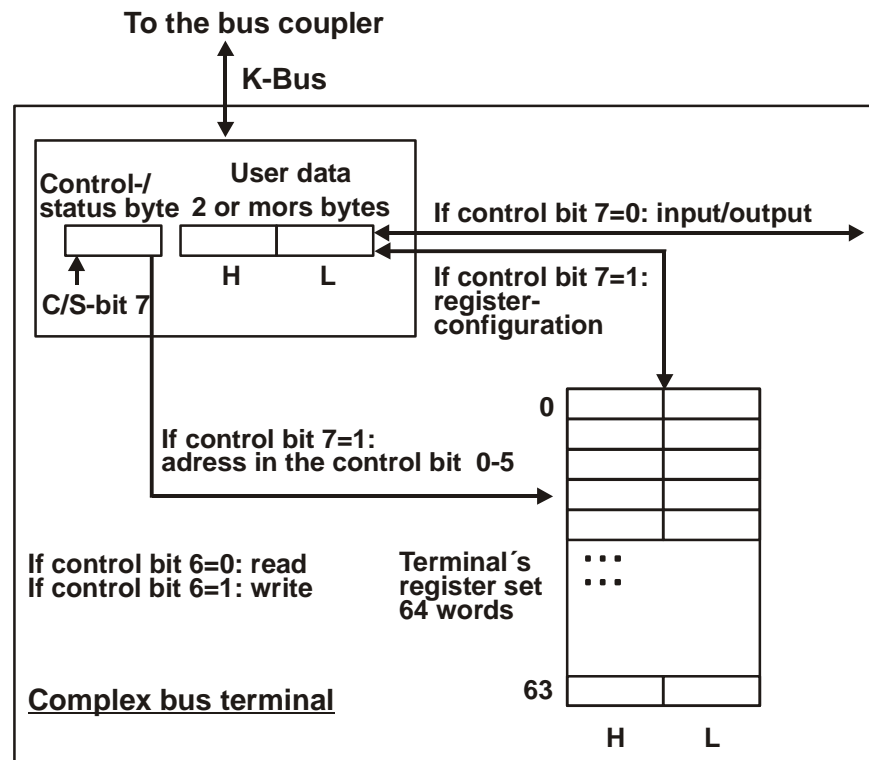

The control or status byte occupies the lowest address of a logical channel. The corresponding register values are located in the following 2 data bytes (the BK2000 is an exception to the rule: here, an unused data byte is inserted after the control or status byte, thus setting the register value to a word limit).

3.4.1 Examples for Register Communication

Example 1

Reading register 8 in the BK2000 with a KI3022 and the end terminal.

If the following bytes are transferred from the controller to the terminal,

Byte	Byte3	Byte2	Byte1	Byte0
Name	Data OUT, low byte	Data OUT, high byte	Not used	Control
Value	0xXX	0xXX	0xXX	0x88

the terminal returns the following type designation (0x0BCE corresponds to the unsigned integer 3022).

Byte	Byte3	Byte2	Byte1	Byte0
Name	Data IN, low byte	Data IN, high byte	Not used	Status
Value	0xCE	0x0B	0x00	0x88

Example 2

Writing register 31 in the BK2000 with an intelligent terminal and the end terminal.

If the following bytes (user code word) are transferred from the controller to the terminal,

Byte	Byte3	Byte2	Byte1	Byte0
Name	Data OUT, low byte	Data OUT, high byte	Not used	Control
Value	0x35	0x12	0xXX	0xDF

the user code word is set and the terminal returns the register address with the bit 7 for register access and the acknowledgement.

Byte	Byte3	Byte2	Byte1	Byte0
Name	Data IN, low byte	Data IN, high byte	Not used	Status
Value	0x00	0x00	0x00	0x9F

4 Appendix

As already described in the chapter terminal configuration, each bus terminal is mapped in the bus coupler. In the standard case, this mapping is done with the default setting in the bus coupler / bus terminal. This default setting can be modified with the KS2000 configuration software or using master configuration software (e.g. ComProfibus or TwinCAT System Manager). The following tables provide information on how the KL1512 maps itself in the bus coupler depending on the set parameters.

4.1 Mapping in the bus coupler

The KL1512 is mapped in the bus coupler with 5 bytes input and 5 bytes output data.

Default Mapping for CAN, DeviceNet, ControlNet, Modbus, RS232 and RS485 Coupler	Conditions	Word offset	High Byte	Low Byte
		Complete evaluation: don't care	0	Ch1 D0
Motorola format: no	1	Ch2 CB/SB	Ch1 D1	
Word alignment: no	2	Ch2 D1	Ch2 D0	

Default-Mapping for Profibus and Interbus Coupler	Conditions	Word offset	High Byte	Low Byte
		Complete evaluation: don't care	0	Ch1 D1
Motorola format: yes	1	Ch2 CB/SB	Ch1 D0	
Word alignment: no	2	Ch2 D0	Ch2 D1	

Default-Mapping for Lightbus and Ethernet Coupler and Bus Terminal Controller (BCxxxx, BXxxxx)	Conditions	Word offset	High Byte	Low Byte
		Complete evaluation: don't care	0	res.
Motorola format: no	1	Ch1 D1	Ch1 D0	
Word alignment: yes	2	res.	Ch2 CB/SB	
	3	Ch2 D1	Ch2 D0	

Conditions	Word offset	High Byte	Low Byte
	Complete evaluation: don't care	0	res.
Motorola format: yes	1	Ch1 D0	Ch1 D1
Word alignment: yes	2	res.	Ch2 CB/SB
	3	Ch2 D0	Ch2 D1

Key

Complete evaluation:

The terminal is mapped with control and status byte.

Motorola format:

Motorola or Intel format can be set.

Word alignment:

The terminal is at word limit in the Bus Coupler.

Ch n SB: status byte for channel n (appears in the input process image).

Ch n CB: control byte for channel n (appears in the output process image).

Ch n D0: channel n, data byte 0 (byte with the lowest value)

Ch n D1: channel n, data byte 1 (byte with the highest value)

res.: reserved:

This byte occupies process data memory, although it is not used.

4.2 Support and Service

Beckhoff and their partners around the world offer comprehensive service and support, making available fast and competent assistance with all questions related to Beckhoff products and system solutions.

4.2.1 Beckhoff Support

Support offers you comprehensive technical assistance, helping you not only with the application of individual Beckhoff products, but also with other, wide-ranging services:

- world-wide support
- design, programming and commissioning of complex automation systems
- and extensive training program for Beckhoff system components

Hotline: +49(0)5246/963-157
Fax: +49(0)5246/963-9157
e-mail: support@beckhoff.com

4.2.2 Beckhoff Service

The Beckhoff Service Centre supports you in all matters of after-sales service:

- on-site service
- repair service
- spare parts service
- hotline service

Hotline: +49(0)5246/963-460
Fax: +49(0)5246/963-479
e-mail: service@beckhoff.com

You will find further support and service addresses on our Internet pages under: <http://www.beckhoff.com>.

4.2.3 Beckhoff company headquarters

Beckhoff Automation GmbH
Eiserstr. 5
D-33415 Verl
Germany

Phone: +49(0)5246/963-0
Fax: +49(0)5246/963-198
e-mail: info@beckhoff.com

The addresses of Beckhoff's branch offices and representatives round the world can be found on the internet pages: <http://www.beckhoff.com>
You will also find further documentation for Beckhoff components there.